

---

# **BELARUS**

# **1220.4**

**with**

# **D-245.2S3A M**

# **(MERCER) engine**

---

**1220.4-0000010-02 OM**

## **OPERATORS MANUAL**

(Supplement to Operators manual of BELARUS 1220.1)

2011

## CONTENTS

1 Tractor description and operation.....	4
1.1 Tractor designation .....	4
1.2 Distinctions of BELARUS -1220.4 model from BELARUS -1220.1 model.....	4
2 Tractor components description and operation .....	4
2.1 General description.....	4
2.2 Electric equipment .....	4
3 Tractor intended use.....	7
4 Maintenance .....	7

The operating manual is intended for study of arrangement, operating rules and maintenance of the tractors "BELARUS -1220.4" with engine D-245.2S3A M.

The present manual is a supplement of operating manual 1220.1 – 0000010 and should be enclosed together with this manual.

Read carefully through this manual, operating manual 1220.1 – 0000010, operating manual for diesel engine 245S3A M – 0000100, enclosed with your tractor. It will help you to get acquainted with methods of proper operation and maintenance.

Failure to follow this instruction can result in operator's injuries and tractor breaks.

Tractor operation, its maintenance and repairing must be carried out only by the specialists, acquainted with all its characteristics and informed about necessary safety requirements to prevent accidents.

Due to constant development of tractor, changes, which are not shown in the present operating manual, can be introduced into design of some assembly units and parts.

All unspecified changes, introduced into structure of any assembly units by the consumer, release the manufacturer from responsibility for subsequent operator's injuries and tractor breakings.

## **1 Tractor description and operation**

### **1.1 Tractor designation**

Tractor "BELARUS -1220.4" is manufactured on the base of tractor "BELARUS -1220.1".

Tractor "BELARUS-1220.4" is designed for executing various agricultural works with mounted, semi-mounted and trailed machines and implements, for loading-unloading operations, transportation works and for driving stationary agricultural machines; they are supplied to consumers in the Republic of Belarus and abroad.

### **1.2 Distinctions of BELARUS -1220.4 model from BELARUS -1220.1 model**

Tractor "BELARUS-1220.4" is equipped with engine D-245.2S3A M manufactured by MMZ with power of 90 kW. Engine conforms to environmental requirement of stage III A according to harmful substance emission.

## **2 Tractor components description and operation**

### **2.1 General description**

Information on technical data, controls, arrangement, adjustments, troubleshooting and tractor "BELARUS-1220.4" systems excluding the engine, are specified in the operating manual 1220.1-0000010.

Distinctions of electric equipment of tractor "BELARUS-1220.4" from electric equipment of tractor "BELARUS -1220.1" are specified in subsection 2.2 "Electrical equipment".

Information on technical data, controls, arrangement, adjustments, troubleshooting of engines of tractor "BELARUS-1220.4" are specified in the engine operating manual 245S3A M – 0000100.

### **2.2 Electric equipment**

Main distinctive feature of electric equipment of tractor "BELARUS-1220.4" from electric equipment of tractor "BELARUS -1220.1" is possibility to connect battery switch lockout relay to the tractor's on-board circuit with the engine running, and the following engine components D-245.2S3A M:

- starting solenoid (enriching unit);
- exhaust gas recirculation control system "MERCER".

Connection diagram for the abovementioned components is shown in Figure 2.2. Remaining electric equipment corresponds to the diagram shown at Page P12 of the operating manual 1220.1-0000010.

Starting solenoid is installed on a fuel injection pump governor. Starting solenoid is designed for disabling of fuel supply limitation mode at zero or low pressure of supercharged air in intake manifold at the moment of engine start. Starting solenoid should be connected to a terminal "ST" of starter and instruments switch with a wire with single-contact socket as shown in Figure 2.1.

When the engine starts power supply voltage of 12V is supplied to the starting solenoid upon starter and instruments switch key turning into position "II" (engine start), traction relay disconnecting pneumatic compensator becomes actuated. Starting solenoid will be disabled after returning starter and instruments switch key into position "I".

Engine exhaust gas recirculation control system is equipped with a fuel pump with "MERCER" system, it engages integrated modular switch energizing electromagnetic recycling valve according to the fuel pump rotation frequency (frequency sensor) and position of cyclic feed metering control rack of fuel injection pump assembly (position sensor).

Connection of "MERCER" control system to the tractor's on-board circuit is performed by means of two-contact socket of the engine cable output as shown in Figure 2.1.

Note – Detailed description of starting solenoid and exhaust gas recirculation control system “MERCER” operation principle are shown in the engine operating manual 245S3A M – 0000100.

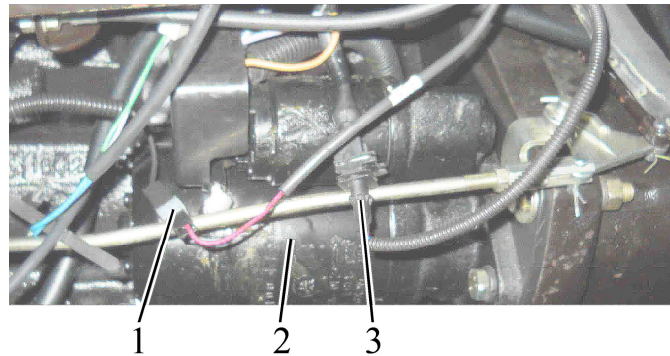

1 – connection of electric power supply to a starting solenoid; 2 – starter; 3 – connection of electric power supply to “MERCER” control system.

Figure 2.1 – Connection of a starting solenoid and “MERCER” control system to the tractor’s on-board circuit.

Table 2.1 – List of the electric connection diagram components shown in Figure 2.2.

Designation	Name	Qty.	Note
A5	Fuel enrichment valve	1	Engine Package
A6	Fuel pump	1	Engine Package
F1, F2	Fuse blocks	2	
G1	Generator 14V, 2000W	1	
GB1, GB2	Accumulator battery 12V, 88Ah	2	
K1	Spark plug relay switch	1	
K2	Instrumentation power supply relay switch	1	
K3	Cut-in relay 30A	1	
K8	Cut-out relay 30A	1	
KT1	Spark plug unit	1	
M3	Starter	1	
QS1	Remote battery disconnect switch 24V	1	
R2	Generator ballast resistor	1	
SA6	Starter switch with starter blocking	1	"COBO", Italy
SA8	Battery disconnect switch	1	
UZ1	Voltage converter	1	
XP2.1, XP2.6, XP2.12	Two-pin male receptacle	3	
XS1.23	Single-pin female receptacle	1	
XS2.8, XS2.23, XS2.26, XS2.27	Two-pin female receptacle	4	
XS7.1	Seven-pin female receptacle	3	
XS2.9	Female receptacle 30-16-06570	1	"COBO", Italy
XS3.3	Female receptacle 30-16-06571	1	"COBO", Italy
	Connecting devices TU BY 500227068.029-2005		
XS12.1	Socket ШС32П12Г-M-7	1	
XS15.1	Socket ШС36У15Г-M-6	1	
XP12.1	Plug ШС32ПК12Ш-MT-7	1	
XP15.1	Plug ШС32ПК12Ш-MT-6	1	

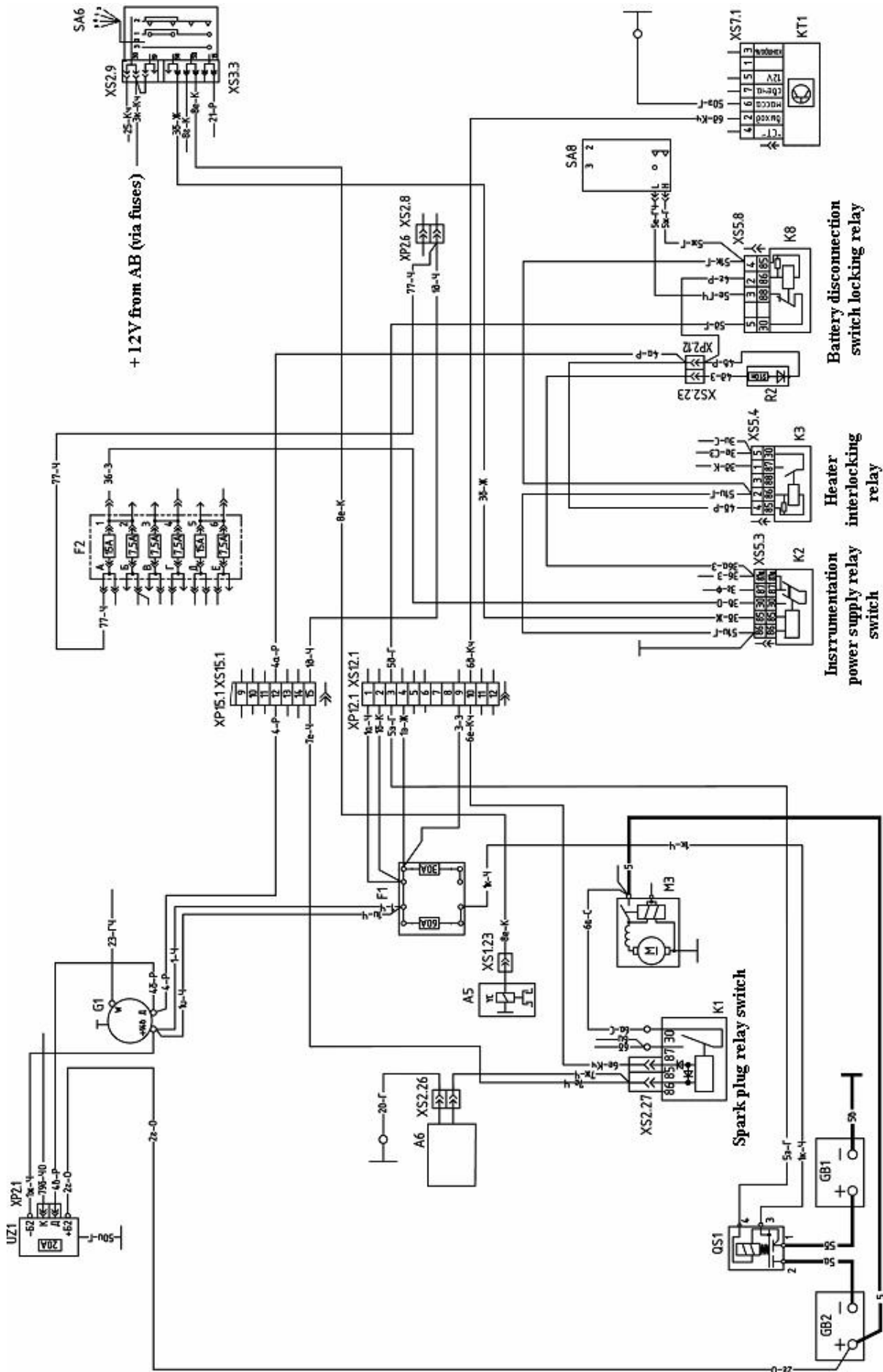

Figure 2.2 – Diagram of connection of lockout relay disconnecting battery switch while engine is running, starting solenoid (enriching unit), exhaust gas recirculation control system “MERCER” to the on-board circuit of tractor “BELARUS-1220.4”.

### **3 Tractor intended use**

Safety precautions, transportation and storage, operating rules of tractors "BELARUS-1220.4" and procedure for implements coupling with it are similar to Safety precautions, transportation and storage, operating rules of tractors "BELARUS-1220.1", and are set forth in the following Sections: "Safety requirements", "Transportation and towing of the tractor", "Tractor storage", "Preliminary starting procedures for tractor", "Operating instructions", "Implement coupling" of the operating manual 1220.1-0000010.

### **4 Maintenance**

Types of scheduled maintenance, maintenance procedures, description of maintenance services, and names, brands, quantity, and periodicity of fuel and lubrication materials change of tractors "BELARUS-1220.4" (including the engine) also are similar to tractors "BELARUS-1220.1", and are set forth in the operating manual 1220.1-0000010.